

Ten-Thermostat + (hygrostat,or timer,or cyclor)

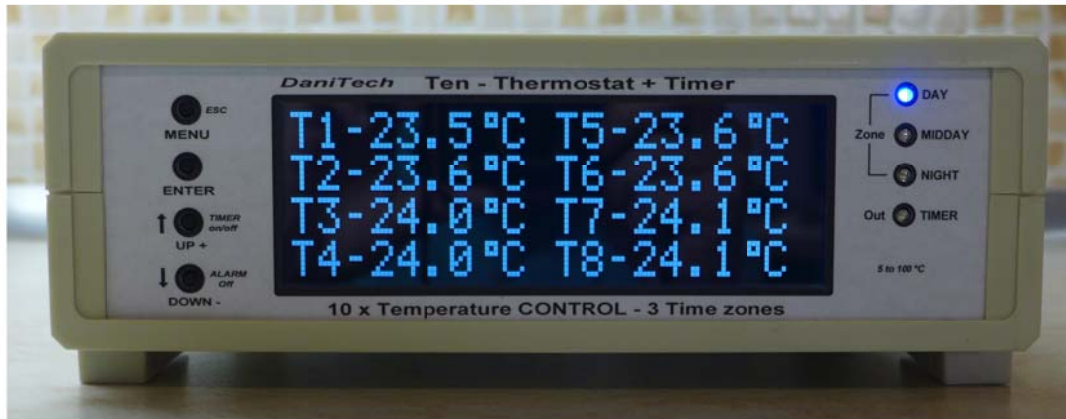

**Thermostat is intended to control temperature in TEN different places.
- humidity control in one place,or timer,or cyclor.
Application: in hatchery, incubator, terrarium, greenhouse.**

Functions:

**10 x Thermostat – heating or cooling
1 x hygrostat,or timer,or cyclor.(choose version)**

Setting:

**Day's temperature 5,0 to 99,9°C, step 0,1°C
Night's temperature 5,0 to 99,9°C, step 0,1°C
Hysteresis 0,1 to 10,0°C, step 0,1°C
Sound alarm of minimum and maximum temperature and humidity
Transition time day/night
Real time
Timer switch on/off time**

Equipment consists of:

**10 x sensor DS 18B20 on the cable of length 3m, it is ended with connector RJ45.
1 x sensor SHT 11 on the cable of length 3m, it is ended with connector RJ11.
11 x output 230VAC, connection by means of terminal board into the section of 1mm²**

Outputs:

**Voltage 230VAC!!!
Fuse 6,3A, common for all outputs
Maximum current 6A
Outputs are designed for connection of 2.class equipment.**

Size:

225 x 85 x 210 mm

Only qualified personnel (knowledge of corresponding EI.standard) is authorized to connect equipment !!!.

DISPLAY

T1-30,0°C +	T5-30,0°C +
T2-30,0°C +	T6-30,0°C +
T3-30,0°C +	T7-30,0°C +
T4-30,0°C +	T8-30,0°C +

MENU:

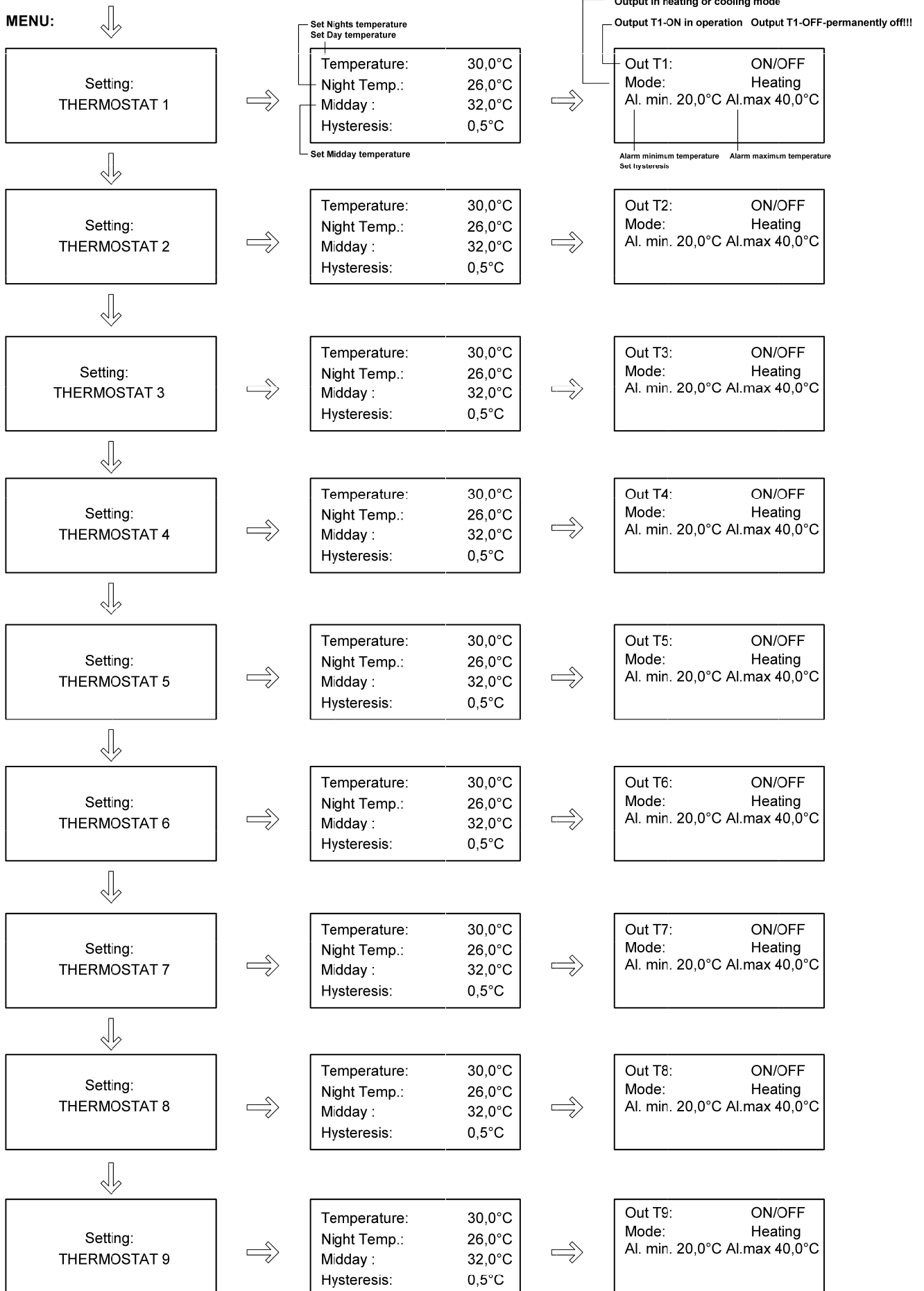

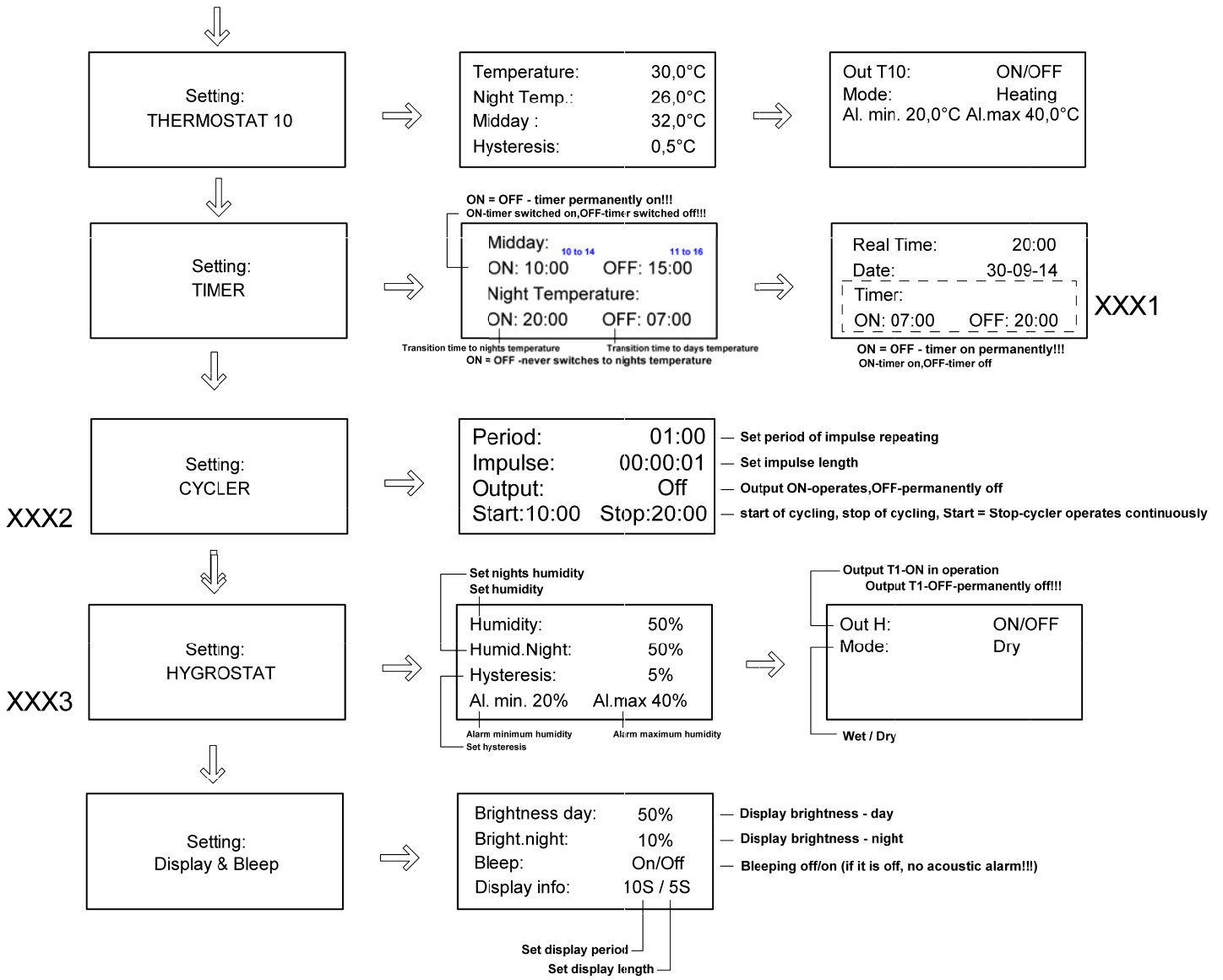

XXX1 - ONLY VERSION WITH TIMER

XXX2 - ONLY VERSION WITH CYCLER

XXX3 - ONLY VERSION WITH HYGROSTAT

first page display

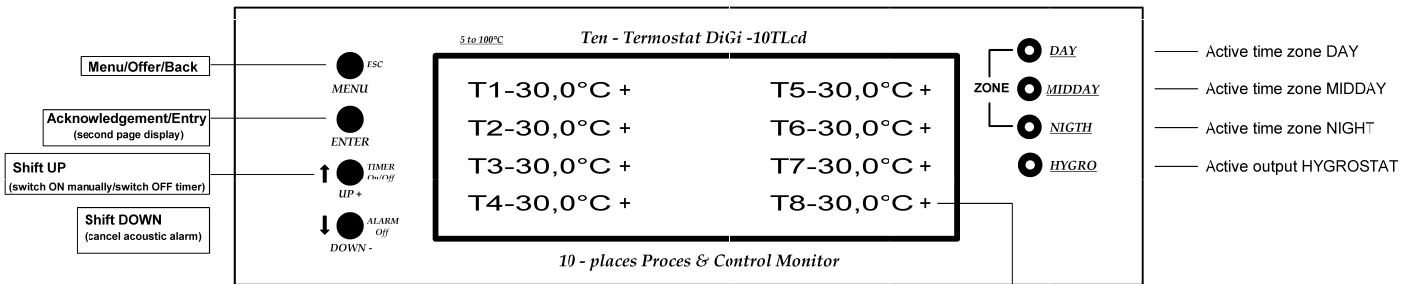

+ - Active heating of outputs T1 to T8
 - - Active cooling of outputs T1 to T8

XXX

next page display

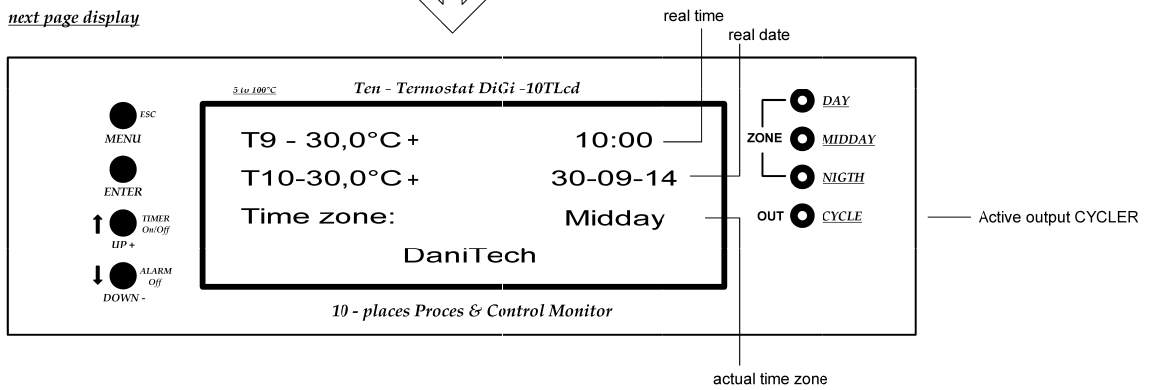

XXX

next page display version + hygrostat

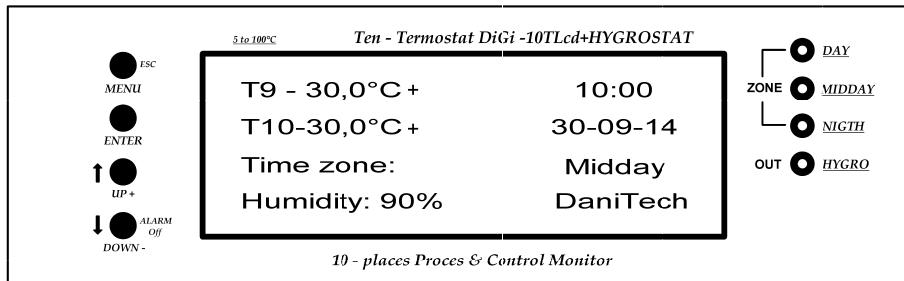

XXX

next page display version + timer

